



RENSON AREAN[®] series

Air to water heat pumps

Installation and maintenance manual

Arean[®] 8 (REN-HP-A-09-V1) • Arean[®] 15(S) (REN-HP-A-15(S)-V1) • Arean[®] 22S (REN-HP-A-22S-V1)

TABLE OF CONTENTS

1. Introduction	3	9. Decommissioning	20
2. Safety instructions	4	9.1. Temporary decommissioning of the heat pump	20
3. Product description	5	9.2. Permanent decommissioning of the heat pump	20
3.1. Renson heat pump concept	5	10. Recycling and disposal	21
3.2. The Areal® heat pump	5	10.1. Disposal of packaging	21
3.3. Unit dimension	6	10.2. Disposal of refrigerant	21
3.4. Application limits	9	11. Technical sheet	22
4. Installation configuration	10	12. Exploded views	24
4.1. Hydraulic installation diagram	10	12.1. REN-HP-A-09-V1	24
4.2. Electric installation diagram	11	12.2. REN-HP-A-15-V1	26
5. Handling & Installation	12	12.3. REN-HP-A-15S-V1	28
5.1. Unit features	12	12.4. REN-HP-A-22S-V1	30
5.2. Choose the right heat pump	12	13. Wiring diagrams	32
5.3. Transit	12	13.1. REN-HP-A-09-V1	32
5.4. What's in the box	12	13.2. REN-HP-A-15-V1	33
5.5. Installation method	13	13.3. REN-HP-A-15S-V1	34
5.6. Installation place	14	13.4. REN-HP-A-22S-V1	35
5.7. Refrigerant charge	15	14. Failure list & Troubleshooting	36
5.8. Water loop connection	15	14.1. Failure handling	36
5.9. Power supply connection	16	14.2. Error code instructions	37
6. Commissioning	17	15. Appendix	40
6.1. Inspection before commissioning	17	15.1. Caution & Warning	40
6.2. Commissioning	17	15.2. Warranty terms and conditions for the user	40
6.3. Trial running	18	15.3. Service	40
7. Handover	18		
7.1. Instructions for the end user	18		
8. Maintenance	19		
8.1. Precautions for daily use	19		
8.2. Periodic maintenance	19		
8.3. Inspection and maintenance	19		
8.4. Cleaning the product	19		
8.5. Checking the evaporator, fan, and condensate discharge	19		

1. INTRODUCTION

In order to provide the customers with high quality, strong reliability and good products, this heat pump is produced by strict design and manufacture standards. This manual includes all the necessary information about installation, debugging, discharging and maintenance. Please read this manual carefully before you open or maintain the unit.

The manufacturer of this product will not be held responsible if someone is injured or the unit is damaged, as a result of improper installation, debugging, unnecessary maintenance which is not in line with this manual.

The unit must be installed by qualified personnel. It is vital that the below instructions are adhered at all times to keep the warranty.

- The unit can only be opened or repaired by a qualified installer or an authorized dealer.
- Maintenance and operation must be carried out according to the recommended time and frequency, as stated in this manual.
- Use only genuine standard spare parts.

Failure to comply with these recommendations will void the warranty.

The Arean® air-to-water heat pump is a high efficient, energy saving and environment friendly product, which is mainly used for house warming. It can work with any kind of heat emitting system such as fan coil, radiator, or floor heating pipe, by providing warm or hot water.

This manual applies to following products:

- Arean® 8 [REN-HP-A-09-V1]
- Arean® 15 [REN-HP-A-15-V1]
- Arean® 15S [REN-HP-A-15S-V1]
- Arean® 22 [REN-HP-A-22-V1]



AREAN® 8 KW



AREAN® 15 KW





AREAN® 22 KW



2. SAFETY INSTRUCTIONS

To prevent users and installers from harm and to avoid damage to the unit or other property, and to use the heat pump properly, please read this manual carefully and understand the following information correctly.





MARK NOTES





Mark	Meaning
 Warning	Wrong operation may lead to death or grievous injury to people.
 Attention	Wrong operation may lead to death or grievous injury to people.

ICON NOTES







Icon	Meaning
 Prohibition	What is prohibited will be nearby this icon.
 Compulsory	The listed action needs to be taken.
 Attention	Please pay attention to what is indicated.

WARNING

Installation	Meaning
 Professional installer required	The heat pump must be installed by qualified persons, to avoid improper installation which can lead to water leakage, electrical shock or fire.
 Earthing required	Please make sure that the unit and power connection have good earthing, otherwise this may cause electrical shock.
Operation	Meaning
 Prohibition	DO NOT put fingers or others into the fan and evaporator of the unit, otherwise harm may occur.
 Shut off power	When there is something wrong or strange smells, the power supply needs to be shut off to stop the unit. Continue running may cause short circuit or fire.

Move and Repair	Meaning
 Only installer	When the heat pump needs to be moved or installed again, please entrust installer to carry it out. Improper installation will lead to water leakage, electrical shock, injury or fire.
 Only installer	It is prohibited to repair the unit by the user himself, otherwise electrical shock or fire may occur.
 Only installer	When the heat pump needs to be repaired, please entrust dealers or qualified people to carry it out. Improper movement or repair on the unit will lead to water leakage, electrical shock, injury or fire.
	Do not use means to accelerate the defrosting process or to clean, other than those recommended by the manufacturer.
	The appliance shall be stored in a room and installed in the environment without continuously operating or potential ignition sources (for example: open flames, an operating gas appliance or an operating electric heater or Electric Spark or hot objects).

ATTENTION

Installation	Meaning
 Location of installation	The unit CANNOT be installed near flammable gases. Once there is any leakage of the gas, fire may occur.
 Fixation of unit	Make sure that the foundation of the heat pump is strong enough, to avoid any decline or fall down of the unit.
 Electrical safety	Make sure that there is circuit breaker for the unit, lack of circuit breaker may lead to electrical shock or fire.
Operation	Meaning
 Foundation of unit	Please check the installation foundation regularly (once a month), to avoid any decline or damage to the foundation, which may hurt people or damage the unit.
 Switch of unit	Please switch off the power when cleaning or maintaining.
 Forbidden	It is prohibited from using copper or iron as fuse. The right fuse must be fixed by electricians for the heat pump.
 Forbidden	It is prohibited from spray the flammable gas to the heat pump, as it may cause fire.

3. PRODUCT DESCRIPTION

3.1. RENSON HEAT PUMP CONCEPT

The Renson heat pump concept consists of an air-to-water heat pump [1], domestic hot water tank [2] and control units [3]. The Arean® heat pump is a R290 monobloc air-to-water heat pump that provides heating and cooling for residential heating and domestic hot water. Domestic hot

water is supplied from a domestic hot water tank connected to the heat pump. Control and cloud connection of the heat pump is done by the Brain module. HVAC components like 3 way valve, domestic hot water sensors are controlled by the HVAC module.

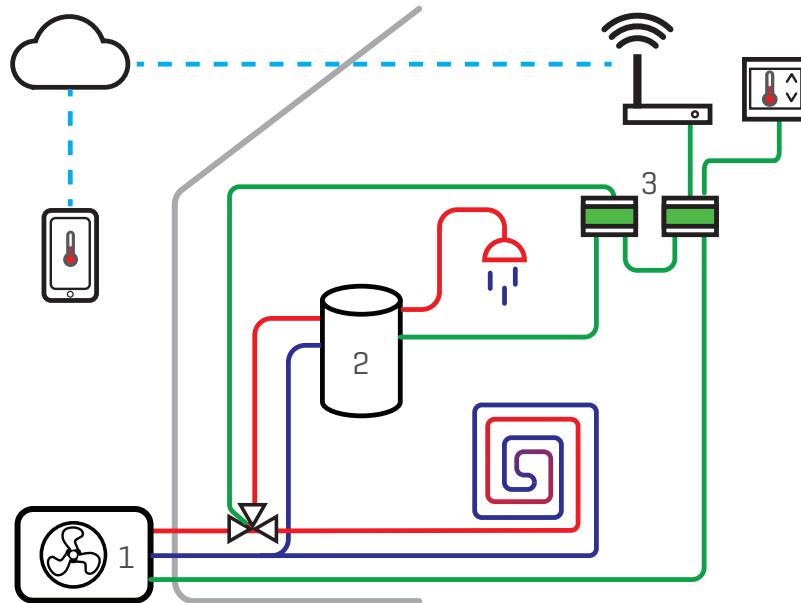

3.2. THE AREAN® HEAT PUMP

This installation manual focuses on the air-to-water unit. The Arean® series heat pumps have following features:

Advanced Controlling

The advanced heat pump logic ensures high performance and proper functioning of the unit. Parameters can be changed easily in the commissioning tool according to the installers preference.

Nice Appearance

Like all Renson products, the heat pumps are designed with an eye for details. The entire product range has a sleek look and feel that completely blends into any environment. The high-quality finish in a matt black colour guarantees a timeless design.

Flexible Installation

The installation of the heat pump is very simple and compact. The system is quick to install, with a limited number of components.

Quiet Running

Both the hardware and the software of the heat pumps have been developed for extremely quiet operation. The silent mode can be enabled manually and automatic to ensure extra quiet operation [see User manual].

Good Heat Exchange Rate

The heat pump unit has a special designed heat exchanger to enhance whole efficiency.

Large Working Range

Thanks to the good performance and properties of the refrigerant R290 the heat pump can work under different working conditions as low as -25 °C for heating.

3.3. UNIT DIMENSION

3.3.1. Model: REN-HP-A-09-V1

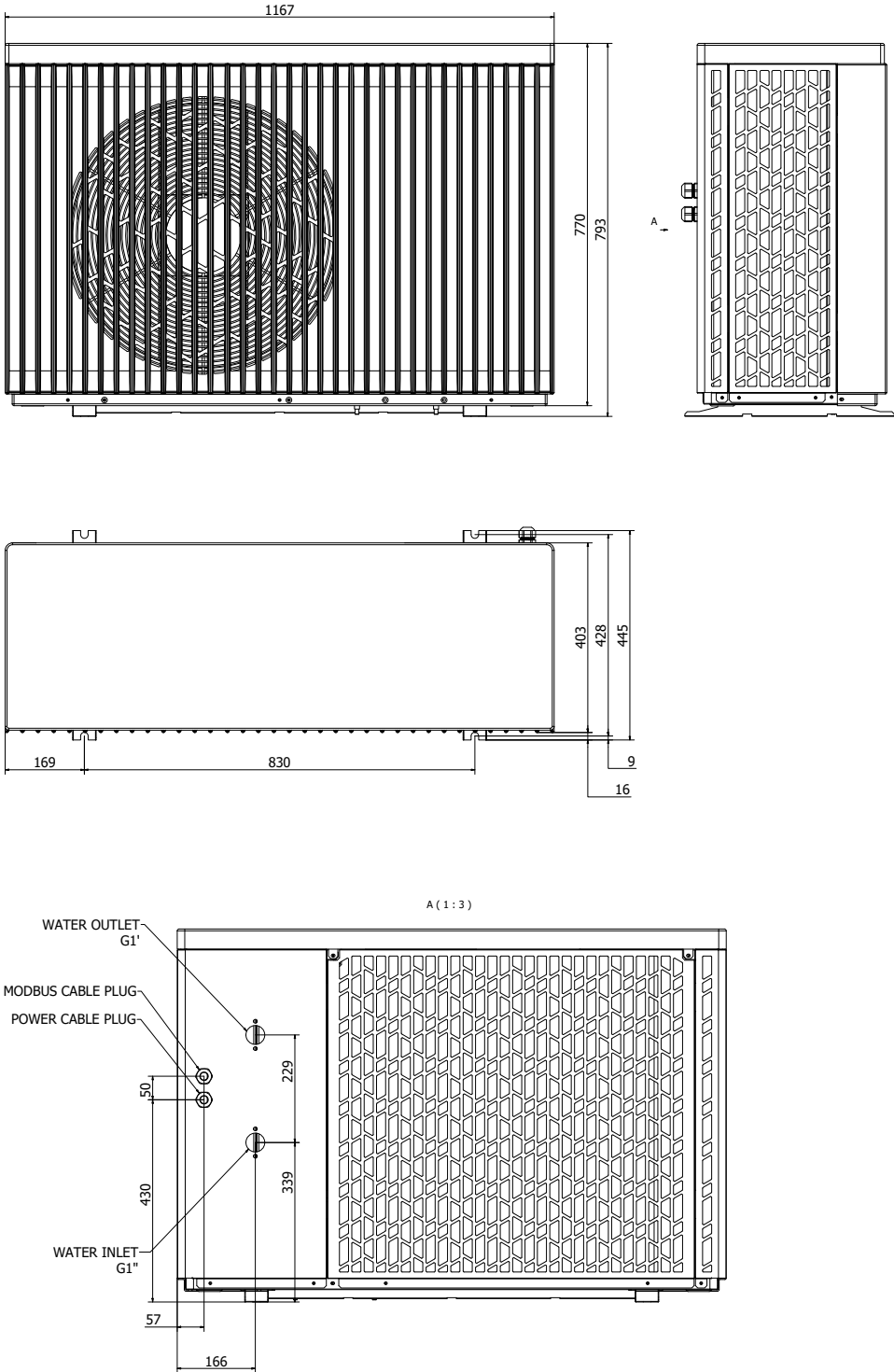

3.3.2. Models: REN-HP-A-15-V1
REN-HP-A-15S-V1

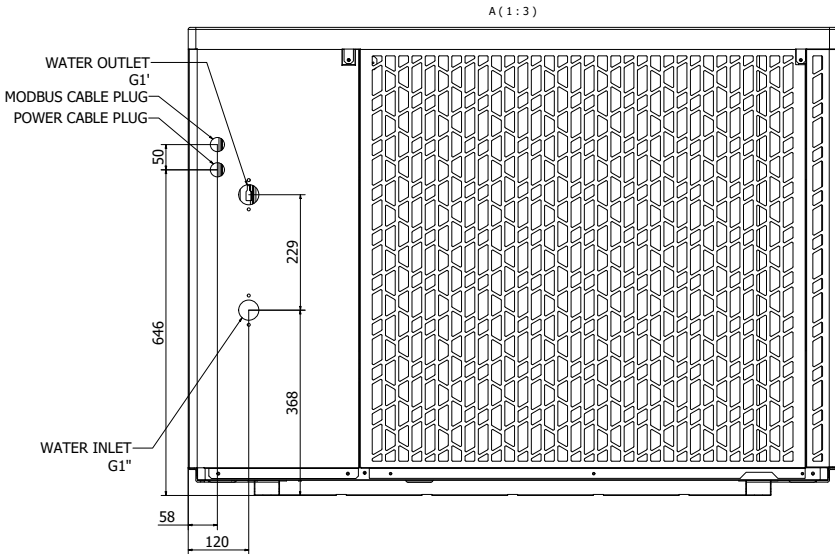
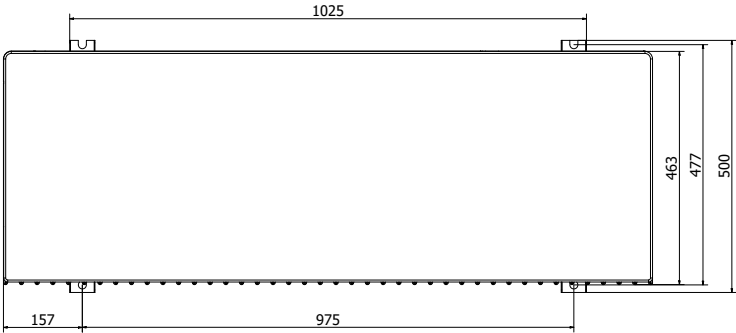
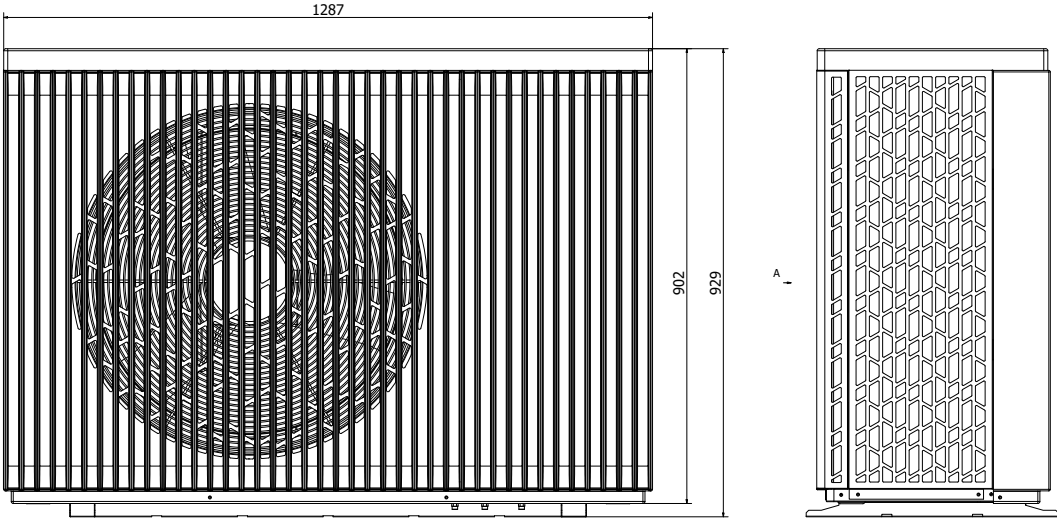

3.3.3. Model: REN-HP-A-22S-V1

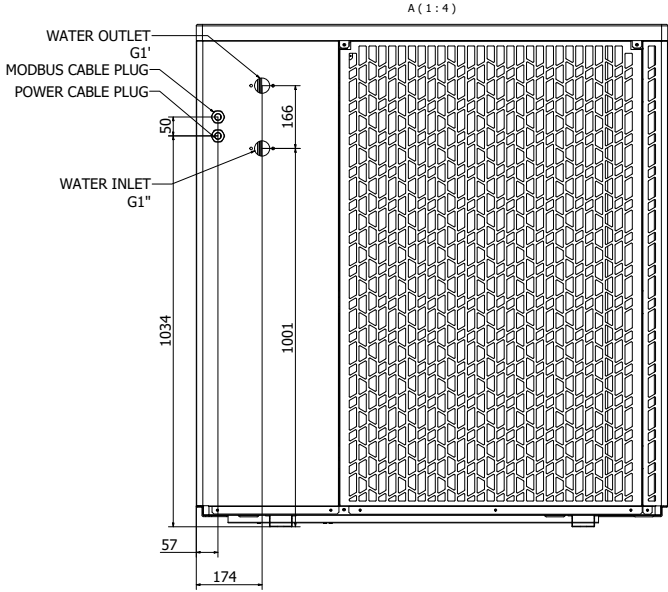
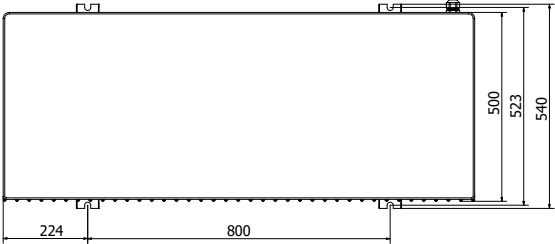
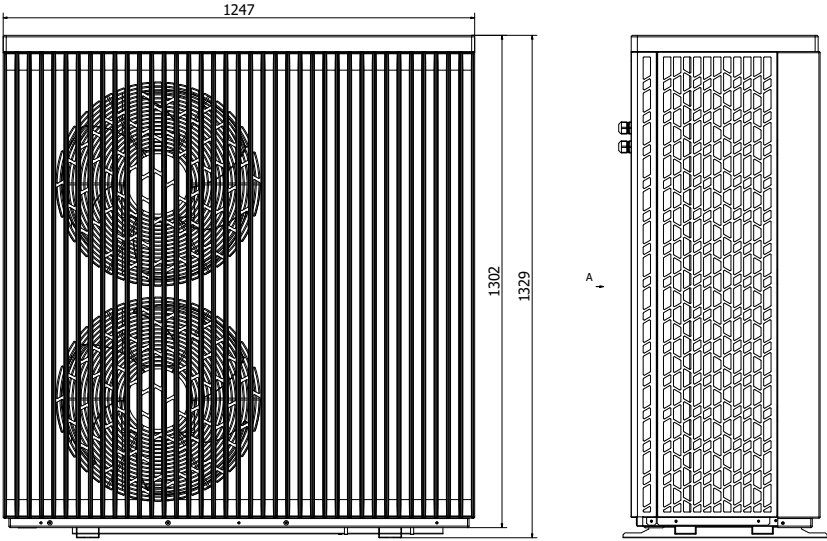

3.4. APPLICATION LIMITS

The heat pump has outdoor temperature limits within which it operates. The application limits in heating, cooling and domestic hot water mode are determined by minimum and maximum outdoor temperatures.

3.4.1. Heating mode

The outdoor temperature limits in heating mode are -25°C to 43°C.

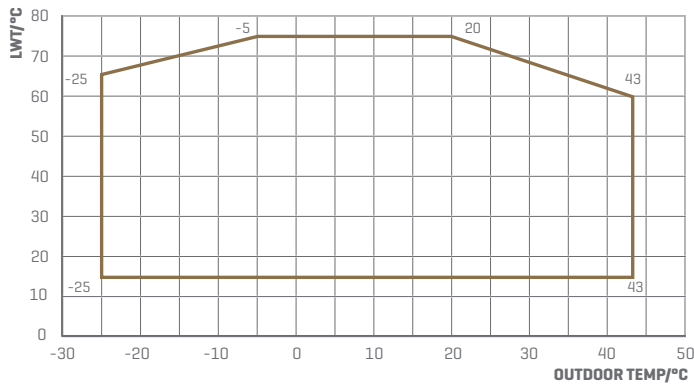

3.4.2. Cooling mode

The outdoor temperature limits in cooling mode are 5°C to 43°C.

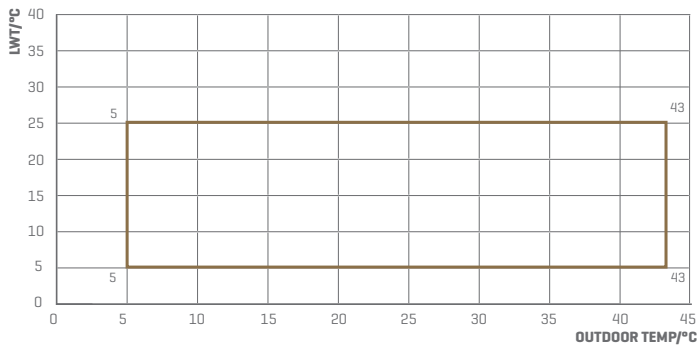

3.4.3. Domestic hot water mode

The outdoor temperature limits in domestic hot water mode are -25°C to 43°C.

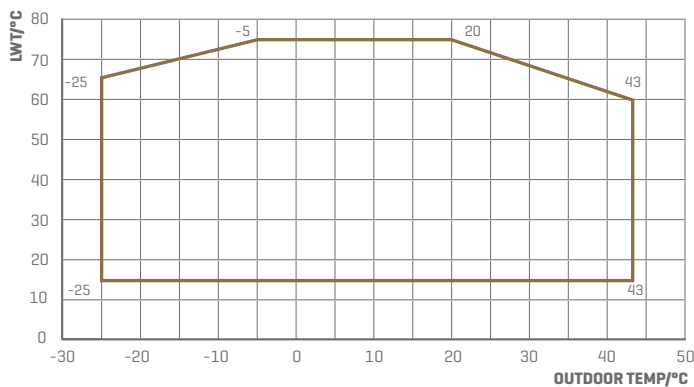

4. INSTALLATION CONFIGURATION

Before installing the Renson heat pump concept it is mandatory to select a hydraulic and electric configuration from the Installation diagram book. This book contains all supported installation configurations. Depending on the desired configuration a different diagram must be chosen. Install both the hydraulic and electronic equipment according to these diagrams. Check the installation diagram book for all possible installation configurations.

Following diagram is an example of an installation diagram for configuration:

- Central heating and domestic hot water
- One water temperature zone
- One thermostat
- No multi-zoning

4.1. HYDRAULIC INSTALLATION DIAGRAM

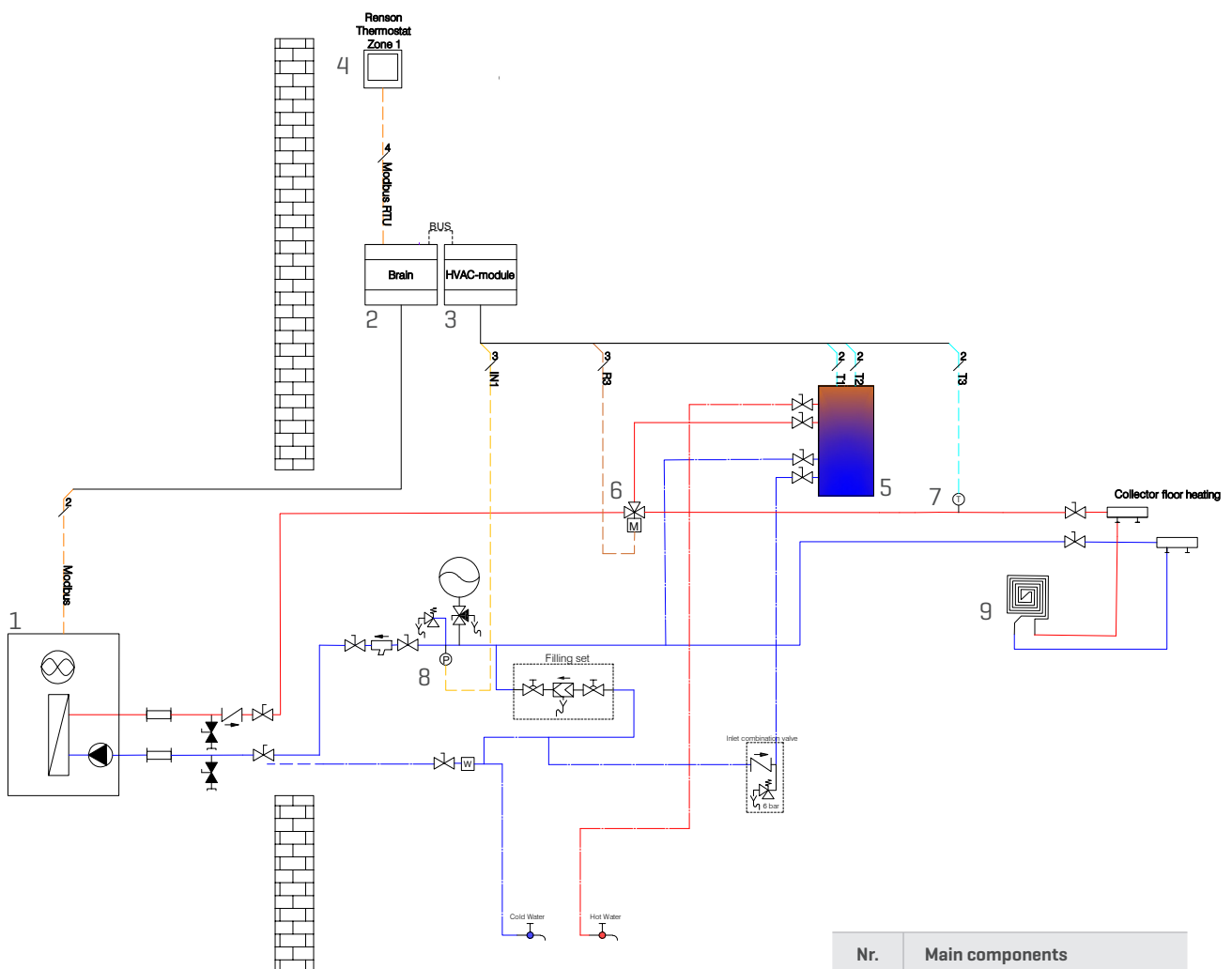

Nr.	Main components
1	Air-to-water heat pump
2	Brain module
3	HVAC module
4	Thermostat
5	Domestic hot water tank
6	3-way-valve
7	Temperature sensor
8	Pressure sensor
9	Heat emitting system

4.2. ELECTRIC INSTALLATION DIAGRAM

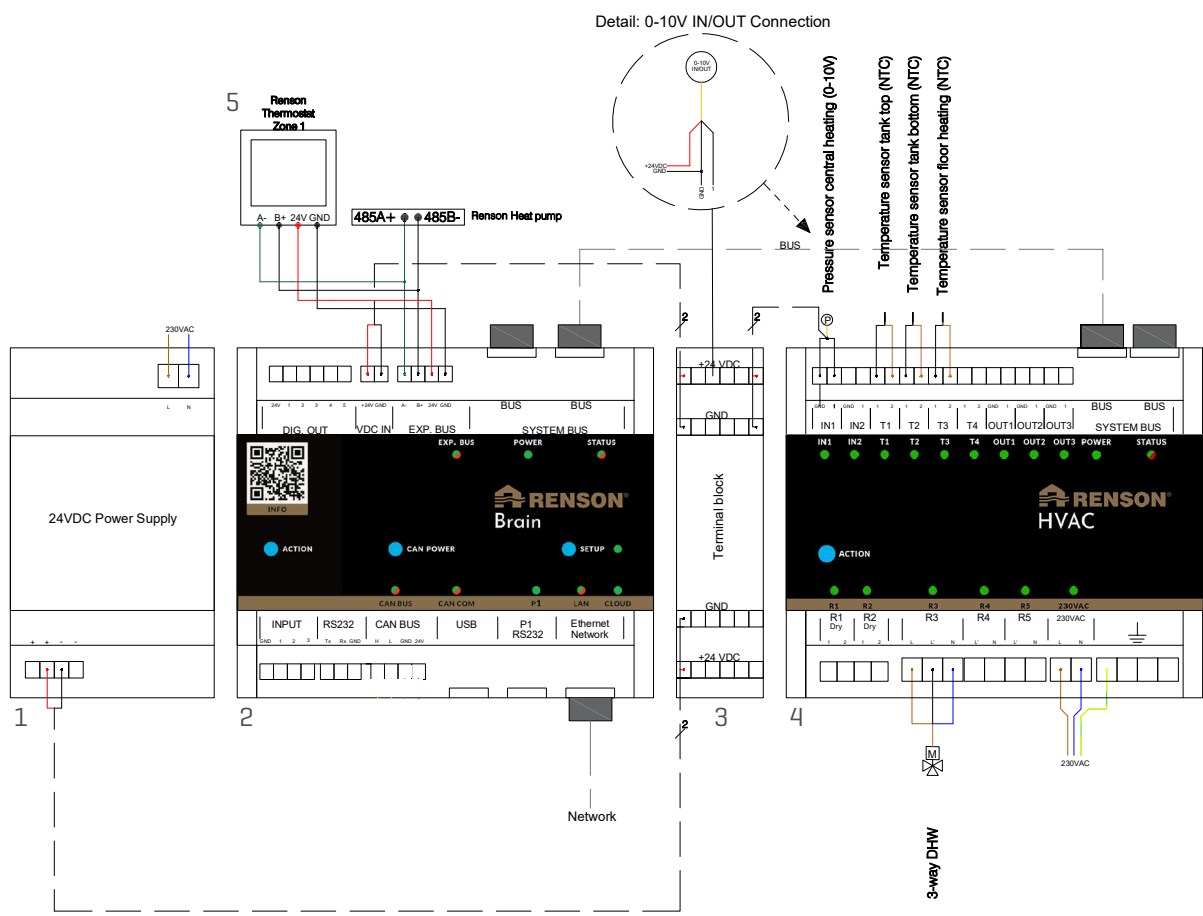

Nr.	Main components
1	24V DC power supply
2	Brain module
3	Terminal block
4	HVAC module
5	Thermostat

5. HANDLING & INSTALLATION

5.1. UNIT FEATURES

a. Plate heat exchanger

The heat pump has a small but very efficient heat exchanger.

b. Environmentally friendly refrigerant

The heat pump has the latest generation of environmentally friendly refrigerant R290, which is harmless to the ozone sphere and has a low global warming potential [GWP=3].

c. Heating in cold environment.

The unit can achieve high outlet temperatures even when the ambient temperature is -25°C.

d. Installation environment

The refrigerant R290 is flammable and explosive. It's prohibited to install in an environment that has a potential ignition sources.

5.2. CHOOSE THE RIGHT HEAT PUMP

1. Based on the local climate condition, construction features and insulation level, it is required to calculate cooling/heating capacity of the building.
2. Conclude the total capacity which will be needed for the building.
3. According to the total capacity needed, choose the right model by consulting the technical sheet.
4. Heat pump features as below:
 - a. For cooling: chilled water outlet temp. at 5-25°C, maximum ambient temp. at 43°C.
 - b. For heating: warm water outlet temp. at 15-75°C, minimum ambient temp. at -25°C.

Unit application: The Renson Arian® air-to-water heat pump can be used for residential buildings (houses and apartments) to provide heating, cooling and domestic hot water.

5.3. TRANSIT

When the unit needs to be lifted up during installation, an 8 meters cable is needed. There must be soft material between the cable and the unit to prevent damage to the heat pump casing [see picture].

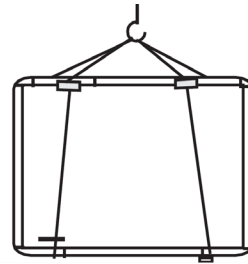

WARNING

DO NOT touch the heat exchanger of the heat pump with fingers or other objects!

5.4. WHAT'S IN THE BOX

Product	Amount	Name
	1	Heat pump
	4	Rubber feet
	1	Eco design label
	1	Manual

Note: depending on the product type, outlook of the product and accessories may differ from the image.

5.5. INSTALLATION METHOD

The heat pump can be installed onto the concrete foundation by expansion screws, or onto a steel frame with rubber feet which can be placed on the ground or rooftop. Make sure that the unit is placed horizontally.

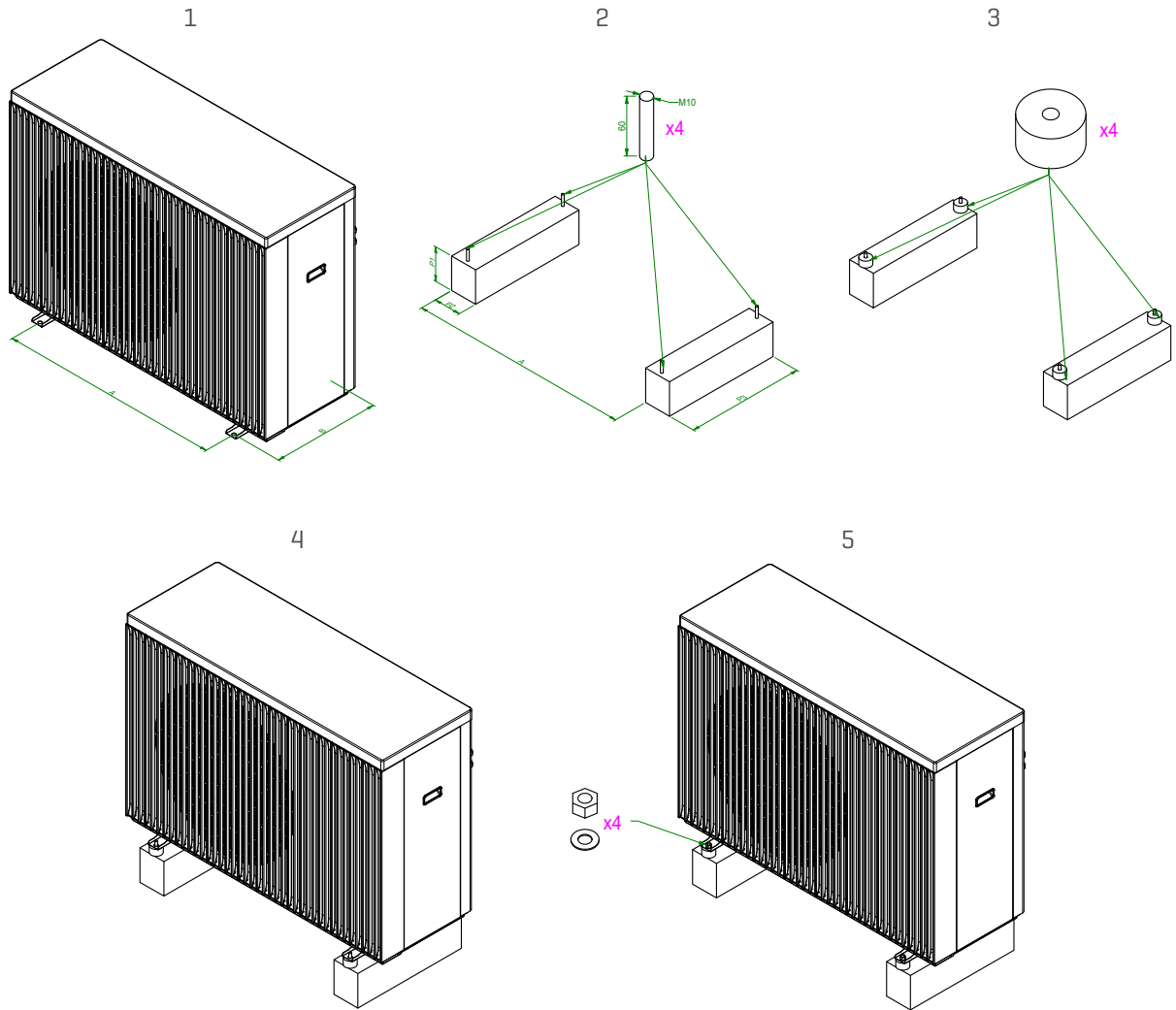

	REN-HP-A-09-V1	REN-HP-A-15-V1	REN-HP-A-15S-V1	REN-HP-A-22S-V1
A	830	975	975	800
B	428	477	477	523
P1	150	150	150	150
P2	120	120	120	120
P3	465	520	520	560

5.6. INSTALLATION PLACE

- a. The unit can be installed on any outdoor place which can carry heavy machinery such as terrace, rooftop, ground and so on.



Take into account possible sound countermeasures for installation on wooden structure.

- b. The location must have good air passage. There must be enough space around the unit for maintenance. Please use minimum distance shown below.

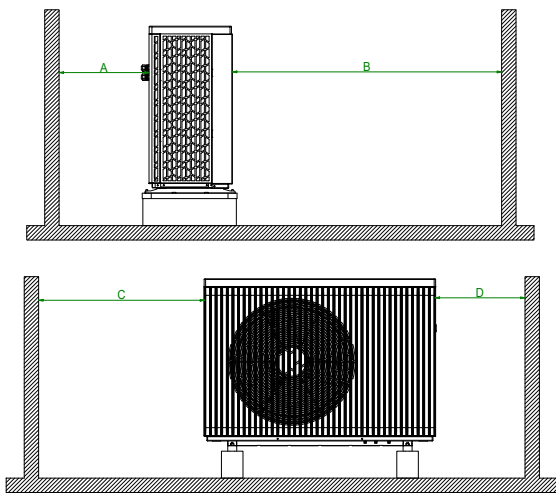

Minimum distance

A > 300 mm

B > 1500 mm

C > 1000 mm

D > 500 mm

- c. The place is free from heat radiation and other fire flame.
- d. There must be no obstacles near the air inlet and outlet of the heat pump. The installation location must be free from strong air blowing.
- e. The installation location must be far away from potential ignition sources (for example: open flames, an operating gas appliance, an operating electric heater, electric spark or hot object).

- f. There must be water channel around the heat pump to drain the condensing water. If the condensing water can not drain freely into the ground, please use a drain pipe to remove the condensing water. Install the drain pipe in one of the drain holes of the bottom plate and close of the remaining holes with the drain stoppers*.

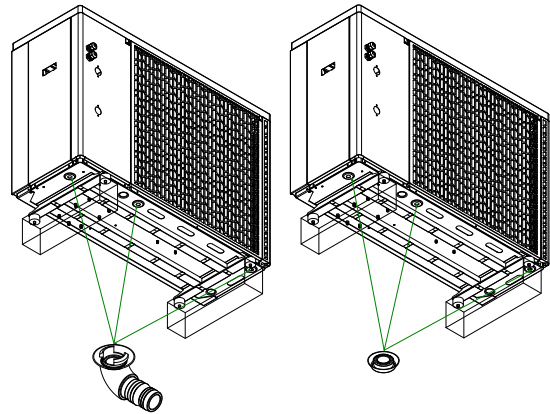

Connect the drain pipe with a hose to lead the condensing water away to a sewer, pump sunk or soak away.

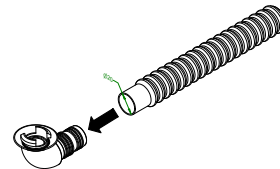

In case of an installation at ground level, the condensing water should be drained via a pipe into the underlying gravel layer. Note for areas with ground frost the thickness of the gravel layer [A] should be at least 900 mm. For areas without ground frost thickness of gravel layer [A] should be at least 600 mm. Make sure both the gravel layer and pipe are large enough for free flow.

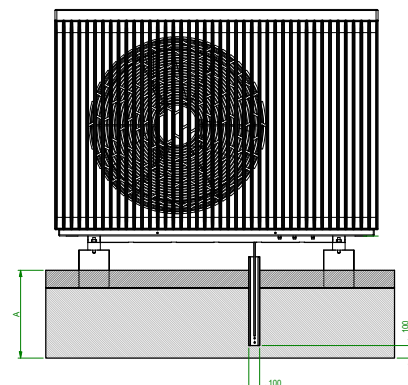

* To be ordered separately

5.7. REFRIGERANT CHARGE

The heat pump is charged with the refrigerant 290 out of factory. When a refrigerant leak has occurred and the unit needs to be recharged, please follow following steps:

5.7.1. Preparations

- Please work in a well-ventilated environment.
- Keep away from open flames or potential sources of fire.
- Disconnect the power supply of the heat pump.

5.7.2. Repair

Find the location of the leak and repair. [Use spanner to remove the seal nut 1 and 3, use 5mm inner hexagon spanner open the valve 2].

5.7.3. Vacuumize

Vacuumize the heat pump. Connect the vacuum pump at the low pressure valve, keep vacuum pump running until the absolute pressure is below 30Pa or the operating time more than one hour.

5.7.4. Charge refrigerant

Keep the refrigerant in liquid state when charging and strictly according to the labeled amount.

Carefully check the nameplate of the heat pump and charge strictly according to the labeled amount.

5.7.5. Finish the charging

After the unit is fully charged, close the valve 2 and screw the seal nut 1 and 3.

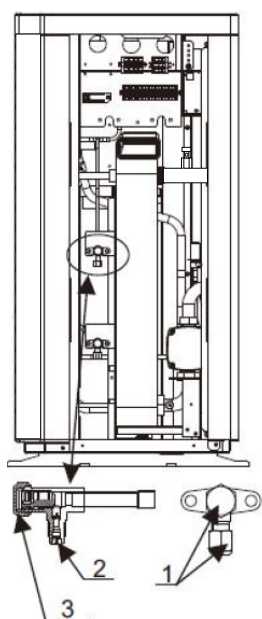

Stop valve signs:
Low pressure

5.8. WATER LOOP CONNECTION

Please pay attention to below matters when the water pipe is connected:

- Select a correct piping diameter to limit pressure drop [depending on the distance between heat pump and indoor hydraulics]. The nominal water flow and the corresponding ESP is mentioned in the technical sheet.

Recommended piping diameters:

- REN-HP-A-09-V1: DN25*
- REN-HP-A-15[S]-V1: DN32*
- REN-HP-A-22S-V1: DN40*



This is only a suggestion from the manufacturer. Installer is responsible for correct pressure drop calculation and selection of correct piping diameter.

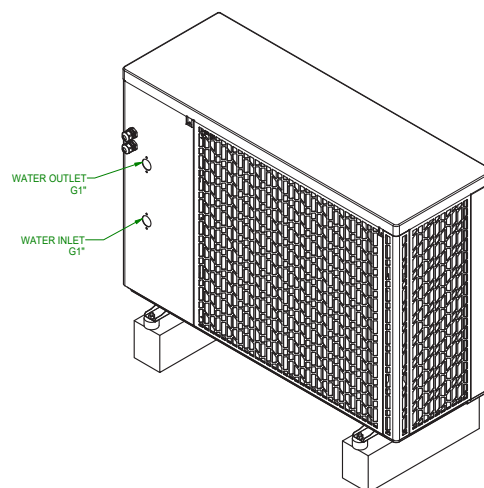

- The piping must be clear and free from dirt and blocks. Water leakage test must be carried out to ensure there is no water leaking. Then the insulation can be installed.
- Be aware that the pipe must be tested by pressure separately. DO NOT test it together with the heat pump.
- There must be expansion vessel on the top point of the water loop, and the water level in the tank must be at least 0.5 meter higher than the top point of the water loop.
- The flow switch is installed inside of the heat pump, check to ensure that the wiring and action of the switch is normal and controlled by the controller.
- Avoid air trapped inside the water pipe, and there must be an air vent on the top point of the water loop.
- There must be a water pressure meter at the water system, for easy inspection during running.

* DN: Internal piping diameter

5.9. POWER SUPPLY CONNECTION

1. Open the side panel by unscrewing the screws of the side panel.

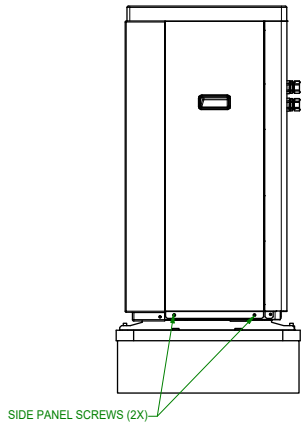

2. Slide the side panel downwards and open the power supply access.

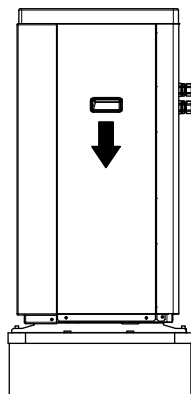

3. The power supply and Modbus cable must go through the wire access

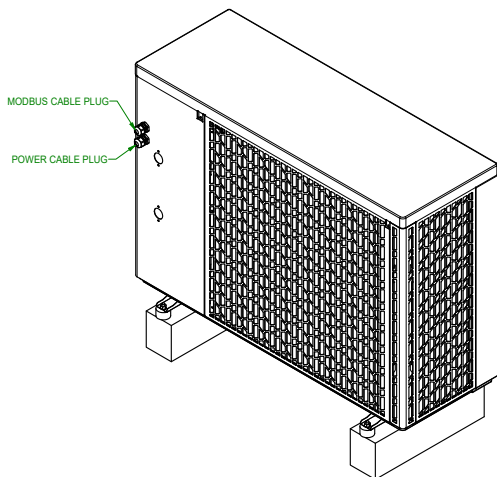

4. Connect the power supply to the terminals in the controlling box. Then connect the 2-wire Modbus cable. Make sure the cables are protected with a pull relief.

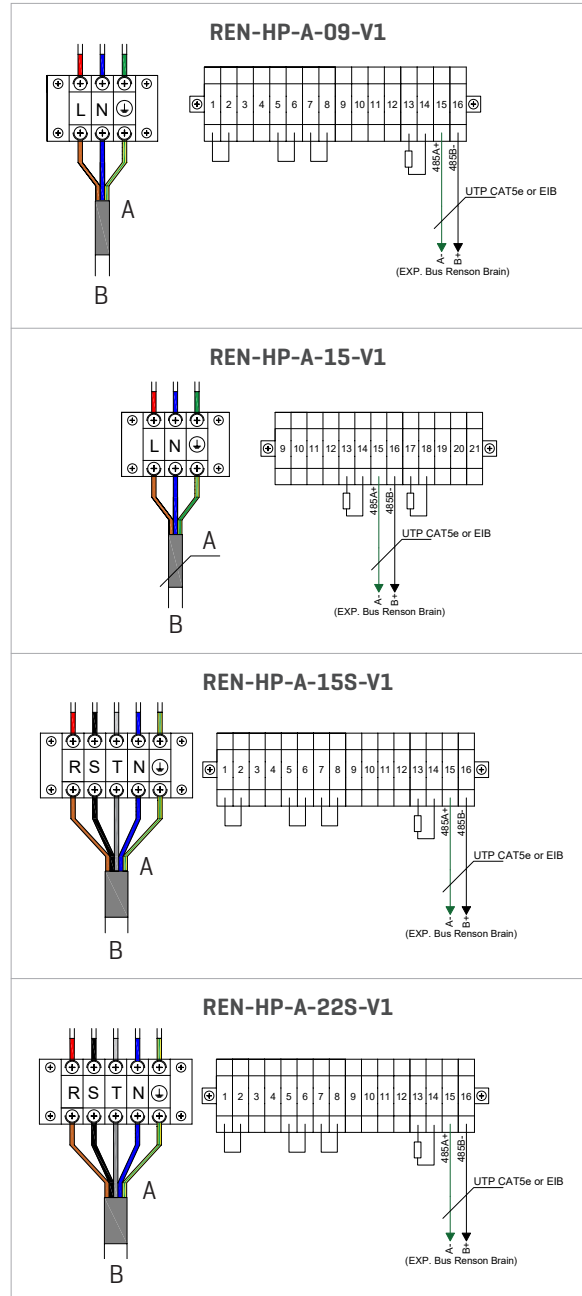

- A** For selection of power cable see technical sheets
B For selection of circuit breaker see technical sheets

6. COMMISSIONING

6.1. INSPECTION BEFORE COMMISSIONING

1. Make sure that the pipe connection is correct and the relevant valves are open.
2. Check the water loop, to ensure that the water inside of the expansion vessel is enough, the water supply is good, the water loop is full of water and without any air. Also make sure there is good insulation around the water piping.
3. Check the electrical wiring. Make sure that the power voltage is normal, the screws are fastened, the wiring

is made in line with the diagram, and the earthing is connected.

4. Check the heat pump unit including all of the screws and parts of the heat pump to see if they are in good order. When the power is on, review the installer tool to see if there is any failure indication. The gas gauge can be connected to the check valves to see the high pressure [or low pressure] of the system during trial running.

6.2. COMMISSIONING

After checking both the hydraulic and electric installation the commissioning of Renson heat pump concept can start. Please use the Renson commissioning tool to

start up the installation. Follow the steps within this tool to complete the installation and ensure a proper functioning of the heat pump system.

6.2.1. Air venting of heat pump

Before the commissioning can start, it is important that the heat pump unit is air vented. The air venting applies only to the heat pump, not the entire water circuit.

1. Fill the water circuit with water.
2. Open the commissioning tool and start the air venting state. The pump will start working.

3. Open the air vents on two locations. Keep them open until no more air comes out of the vent and until flow rate is shown on the commissioning portal.

4. Close the air vents.
5. Switch the air venting state off in the commissioning tool. The pump will switch off.

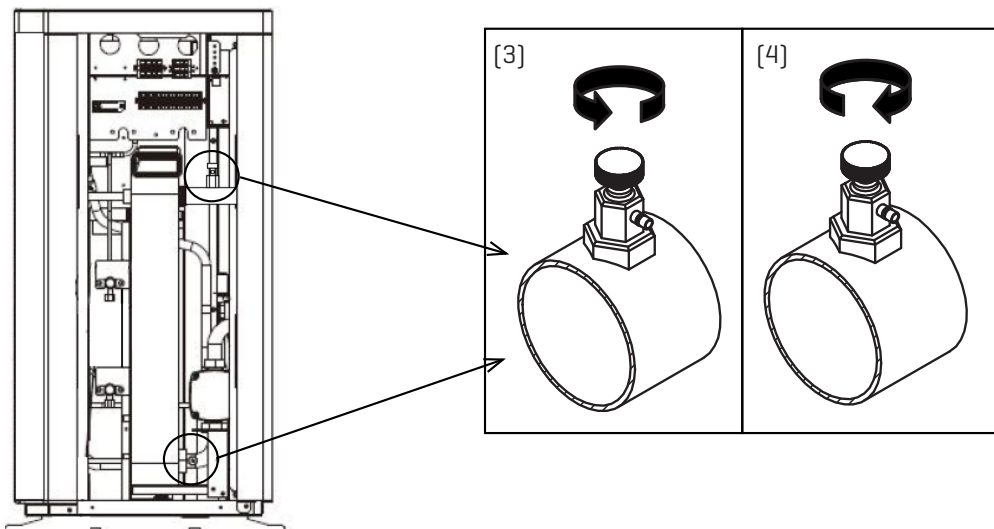

6.3. TRIAL RUNNING

1. There are 3 test conditions for trial running:

- **Heating test:** the unit is placed into heating mode
- **Cooling test:** the unit is placed into cooling mode
- **DHW test:** the unit is placed into DHW mode. When a DHW tank is installed check the correct position of the 3-way valve. If not, change the polarity in the installer portal.

These 3 tests are temporary. End them when check is finished

2. When the water pump runs for 1 minute, the compressor will start. Listen whether there is a strange sound coming from the compressor. If an abnormal sound occurs please stop the unit and check the compressor. If the compressor runs well please look for the pressure meter of the refrigerant.

3. Check whether the power input and running current is in line with the manual. If not please stop and check.

4. Adjust the valves on the water loop, to make sure that the hot [cool] water supply is good and that it meets the requirement of heating [or cooling]. Review whether the outlet water temperature is stable.

5. The parameters of installer portal are set by the factory, the user is not allowed to change them by himself.



If the water flow rate is lower than 70% of the rated water flow, the defrosting efficiency will be lower. The suggested water flow rate shall be the rated flow rate which is shown on the nameplate. The max external static pressure of the pump can be found in the technical data sheet.

7. HANDOVER

7.1. INSTRUCTIONS FOR THE END USER

Please explain to the end users the specifications of the installation and the different components within the installation.

Indicate to the end user:

- Safety warnings
- The risks and rules concerning the refrigerant R290
- The need for regular maintenance for an optimal operation of the installation and all of its components

In case of malfunctioning, please contact the Renson installer.

8. MAINTENANCE

8.1. PRECAUTIONS FOR DAILY USE

- Before starting up the unit for the first time or after a long-time shutdown, the following preparations must be made:
 1. Thoroughly inspect and clean up the unit.
 2. Clean the waterway system.
 3. Check water pump, regulating valve and other waterway equipment.
 4. Tighten all wire connections.
- Do not change the system parameters before consulting the installer or manufacturer.
- Ensure the waterways are clean and avoid dirt and blockage.
- Timely check the electricity, water and replace the faulty parts. Please use the parts provided or recommended by Renson, do not use the unqualified parts.
- Refrigerant supplement:
Each unit has been equipped with sufficient refrigerant when leaving the factory. Do not charge or change the refrigerant. If you need to replenish the refrigerant due to leakage, please contact the installer.

8.2. PERIODIC MAINTENANCE

Preparation

Before maintenance, please ensure that the unit stops running and cut off the power supply.

Inspection and cleaning of fin heat exchanger

In order to ensure that heat exchangers remain in optimum condition for heat exchange, their surfaces must be cleaned every 6 months.

Inspection and cleaning of plate heat exchanger

Every 2 years or when the capacity of the unit drops by more than 10%, check the water-side heat exchanger for scale and clean the heat exchanger. For this, rinsing valves must be installed [see installation diagram].

Check the electrical wiring

Check if the contact point is loose, oxidized, or blocked by sundries, etc., which causes poor contact of the electronic wiring.

8.3. INSPECTION AND MAINTENANCE

8.3.1. Preparing for inspection and maintenance

DANGER!

Risk of death caused by fire or explosion if there is a refrigerant leakage!

Only carry out the work if you are competent and have knowledge about the special features and risks of R290 refrigerant.

The product contains combustible refrigerant R290. In the event of a leak, escaping refrigerant may mix with air to form a flammable atmosphere. There is a risk of fire and explosion.

Ensure that space is sufficiently aerated around the product.

Observe the basic safety rules before carrying out inspection and maintenance work or installing spare parts.

Disconnect the product from the power supply but ensure that the product is still earthed.

8.4. CLEANING THE PRODUCT

Do not clean the product with a high-pressure cleaner or a direct jet of water. Clean the product using a sponge and hot water with a cleaning agent. Do not use abrasive cleaners. Do not use solvents. Do not use any cleaning agents that contain chlorine or ammonia.

8.5. CHECKING THE EVAPORATOR, FAN, AND CONDENSATE DISCHARGE

Check whether there is dirt between the fins or whether depositions have adhered to the fins.

Clean the fins using a soft brush, avoid fins from being bent.

Check whether dirt has been accumulated on the condensate tray or in the condensate discharge pipe.

Check whether the water can drain freely.

9. DECOMMISSIONING

9.1. TEMPORARY DECOMMISSIONING OF THE HEAT PUMP

1. Switch of all circuit breakers connected to the heat pump.
2. Disconnect the product from the power supply. See chapter 5.9 for more info regarding power connections.
3. In case of freezing temperatures, drain the heating water from the heat pump to prevent damage.

9.2. PERMANENT DECOMMISSIONING OF THE HEAT PUMP

1. Switch of all circuit breakers connected to the heat pump.
2. Disconnect the product from the power supply. See chapter 5.9 for more info regarding power connections.
3. Drain the heating water from the heat pump.
4. Remove the side panel and remove the refrigerant. Recycle the removed refrigerant in accordance with the regulations. The refrigerant must be cleaned and checked before it is used again. See chapter 5.7 for more info concerning refrigerant.
5. Label the heat pump with a sticker that it has been decommissioned, all refrigerant has been removed and date of decommissioning.
6. Dispose of or recycle the product and its components in accordance with the regulations.

10. RECYCLING AND DISPOSAL

10.1. DISPOSAL OF PACKAGING

Dispose all packaging material according to regulations.

10.2. DISPOSAL OF REFRIGERANT

Only qualified installers can dispose the refrigerant according to the regulations.



R290 refrigerant is a flammable gas. There is a risk of fire and explosion, when wrongly handled or transported. Ensure that the refrigerant is transported correctly.

11. TECHNICAL SHEET

	Arean® 8	Arean® 15	Arean® 15S	Arean® 22S
				
TYPE				
Order number	86000001	86000002	86000003	86000004
Type number	REN-HP-A-09-V1	REN-HP-A-15-V1	REN-HP-A-15S-V1	REN-HP-A-22S-V1
Colour	Black	Black	Black	Black
Outdoor unit	Monobloc	Monobloc	Monobloc	Monobloc
Input/output	Air/water	Air/water	Air/water	Air/water
Capacity	8kW	15kW	15kW	22kW
MAX. HEATING CAPACITY A 7°C , LEAVING WATER TEMP 35°C				
Heating capacity	7,80kW	14,00kW	14,95kW	22,00kW
Power input	1,91kW	3,85kW	3,85kW	5,32kW
COP	4,08	3,64	3,88	4,13
MAX. HEATING CAPACITY A -7°C , LEAVING WATER TEMP 35°C				
Heating capacity	5,80kW	10,80kW	10,70kW	16,13kW
Power input	2,31kW	4,06kW	4,06kW	5,25kW
COP	2,51	2,66	2,64	3,07
ELECTRICAL CHARACTERISTICS				
Level of protection	IPX4	IPX4	IPX4	IPX4
Phase	1ph	1ph	3ph	3ph
Supply voltage	220~240V	220~240V	380~415V	380~415V
Frequency	50Hz	50Hz	50Hz	50Hz
Rated power*	3kW	5,3kW	5,3kW	9kW
Rated current**	13,5A	24,5A	10,5A	15,8A
REFRIGERATION CHARACTERISTICS				
Max. pressure	3,2MPa	3,2MPa	3,2MPa	3,2MPa
Compressor type	Rotary	Rotary	Rotary	Rotary
Refrigerant	R290	R290	R290	R290
GWP	3	3	3	3
Refrigerant charge	0.5kg	0,85kg	0,85kg	1,30kg
CO ² equivalent	0,0015ton	0,0026ton	0,0026ton	0,0039ton
Expansion valve	Electronic	Electronic	Electronic	Electronic

* For selection of power cable follow national regulations

** For selection of current circuit breaker a safety factor of 1,2 is recommended



GENERAL CHARACTERISTICS

Size unit HxWxD	793x1167x403 mm	929x1287x463 mm	929x1287x463 mm	1329x1247x500 mm
Size packaging HxWxD	940x1300x485 mm	1080x1420x540 mm	1080x1420x540 mm	1480x1380x570 mm
Weight unit	80kg	160kg	160kg	202kg
Weight unit + packaging	102,5kg	182,5kg	182,5kg	224,5kg
Weight packaging	22,5kg	22,5kg	22,5kg	22,5kg
Water connections inlet/outlet	G1"	G1"	G1"	G1"
Min. water volume system	90L	130L	130L	220L
Min.-max. working pressure	0,5-4 bar	0,5-4 bar	0,5-4 bar	0,5-4 bar

PUMP CHARACTERISTICS

Nominal water flow	1m ³ /h	1,7m ³ /h	1,7m ³ /h	2,9m ³ /h
ESP [external static pressure] nom. water flow	55kPa	35kPa	35kPa	60kPa
Max. power pump	60W	60W	60W	180W
EEl	≤0,20	≤0,20	≤0,20	≤0,23

12. EXPLODED VIEWS

12.1. REN-HP-A-09-V1

Explosion diagram of complete machine structure

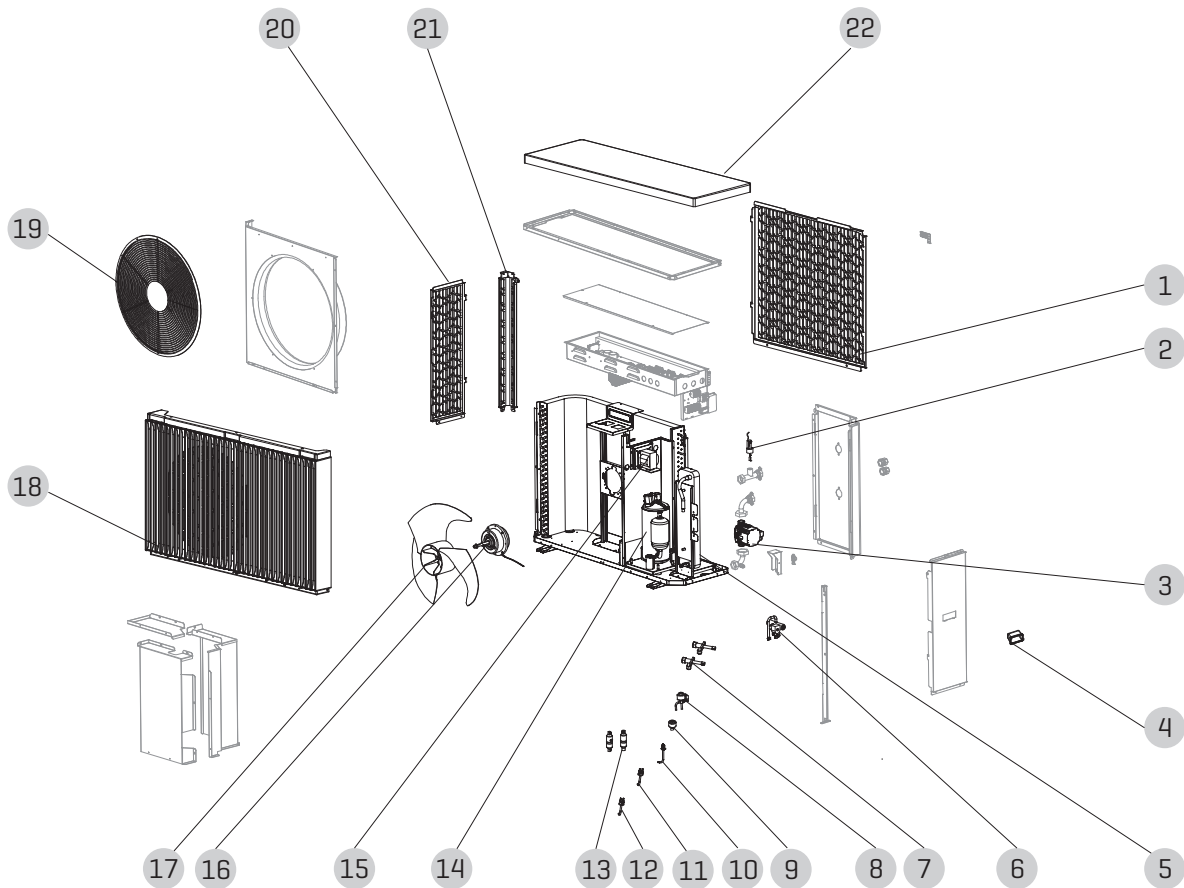

Explosion diagram of electrical box structure

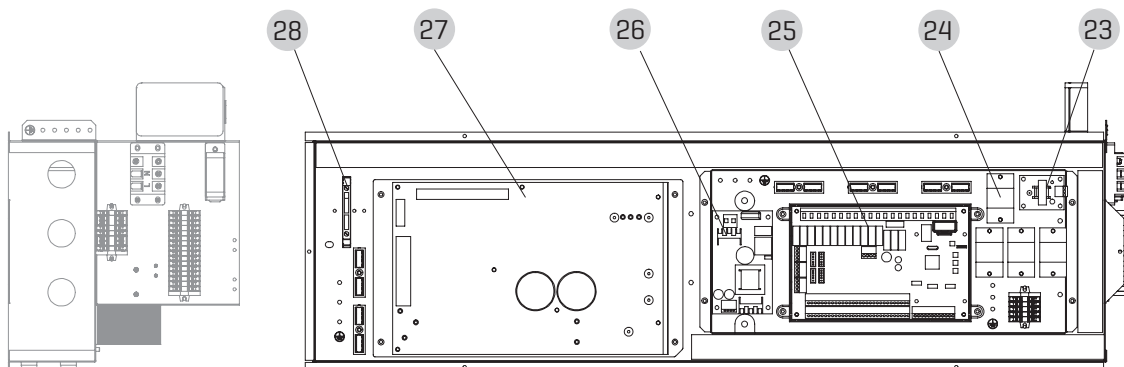

Number	Material code	Material name
1	86000076	Back plate
2	86000038	Water flow switch
3	86000039	Water pump
4	86000041	Handle
5	86000042	Plate heat exchanger
6	86000045	Four way valve and accessories
7	86000028	Stop valve 3/8
8	86000048	Electronic expansion valve
9	86000051	Pressure sensor
10	86000029	Needle valve
11	86000052	Pressure switch [high]
12	86000053	Pressure switch [low]
13	86000054	Filter
14	86000056	Compressor and accessories
15	86000036	Reactor
16	86000060	DC fan motor
17	86000033	Axial fan blade
18	86000074	Front plate
19	86000030	Fan guard
20	86000078	Side plate
21	86000077	Corner plate
22	86000075	Top plate
23	86000063	BHB21
24	86000064	Relay
25	86000065	Main board [PC4003-G]
26	86000066	Power switching module
27	86000068	3P DC Inverter drive board
28	86000067	Fuse terminal

12.2. REN-HP-A-15-V1

Explosion diagram of complete machine structure

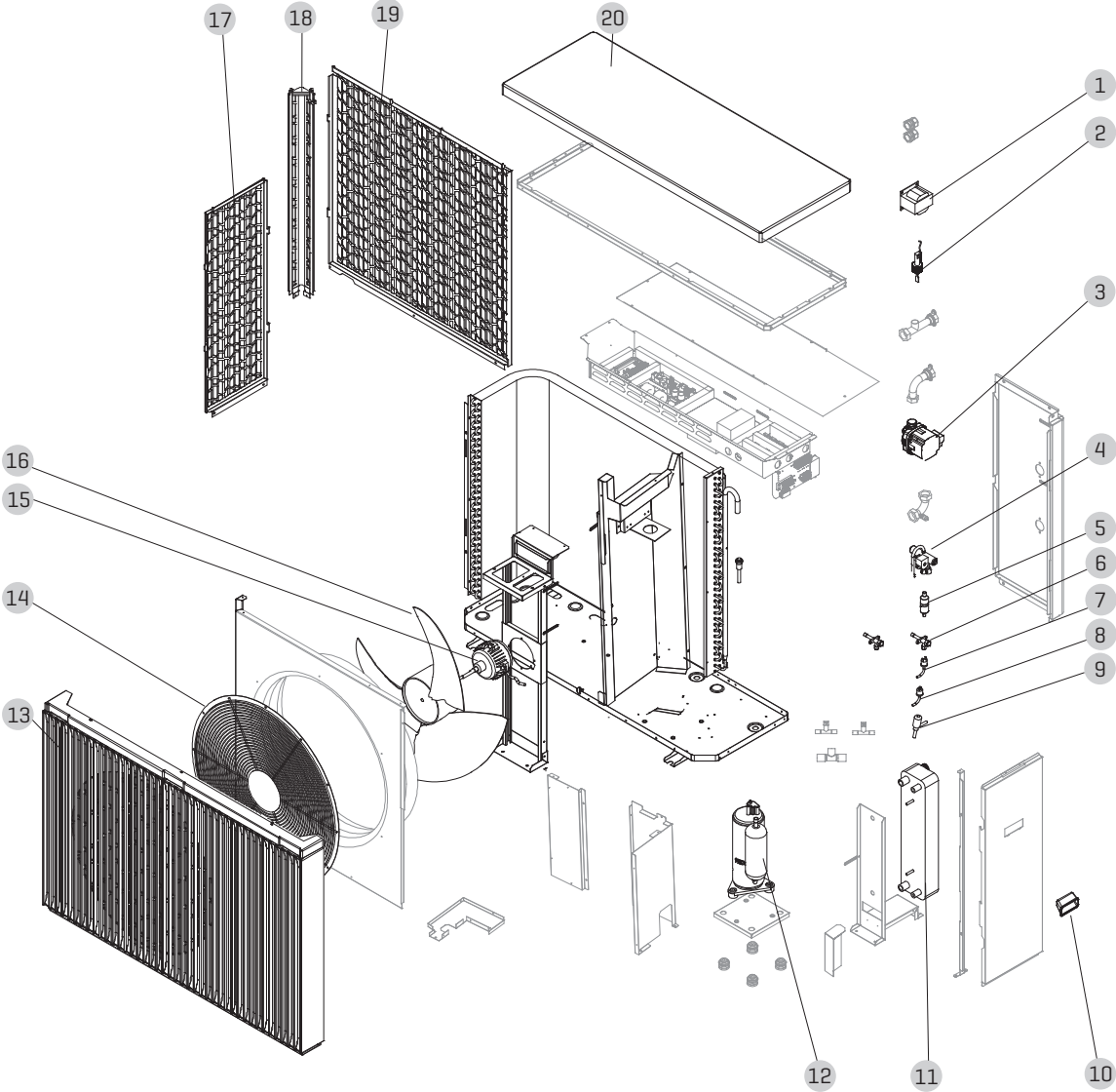

Explosion diagram of electrical box structure

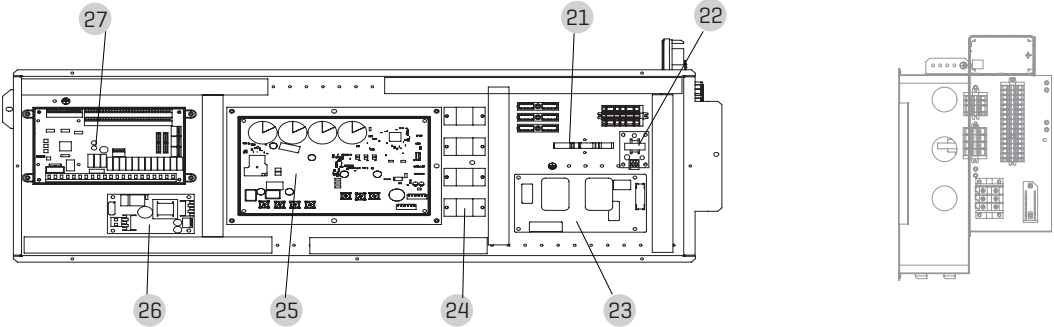

Number	Material code	Material name
1	86000037	Reactor
2	86000038	Water flow switch
3	86000039	Water pump
4	86000046	Four way valve and accessories
5	86000054	Filter
6	86000028	Stop valve 3/8
7	86000052	Pressure switch [high]
8	86000053	Pressure switch [low]
9	86000049	Electronic expansion valve
10	86000041	Handle
11	86000043	Plate heat exchanger
12	86000057	Compressor and accessories
13	86000079	Front plate
14	86000031	Fan guard
15	86000061	DC fan motor
16	86000034	Axial fan blade
17	86000083	Side plate
18	86000082	Corner plate
19	86000081	Back plate
20	86000080	Top plate
21	86000067	Fuse terminal
22	86000063	BHB21
23	86000069	Inverter drive filter board
24	86000064	Relay
25	86000070	Inverter drive module assembly
26	86000066	Power switching module
27	86000065	Main board [PC4003-G]

12.3. REN-HP-A-15S-V1

Explosion diagram of complete machine structure

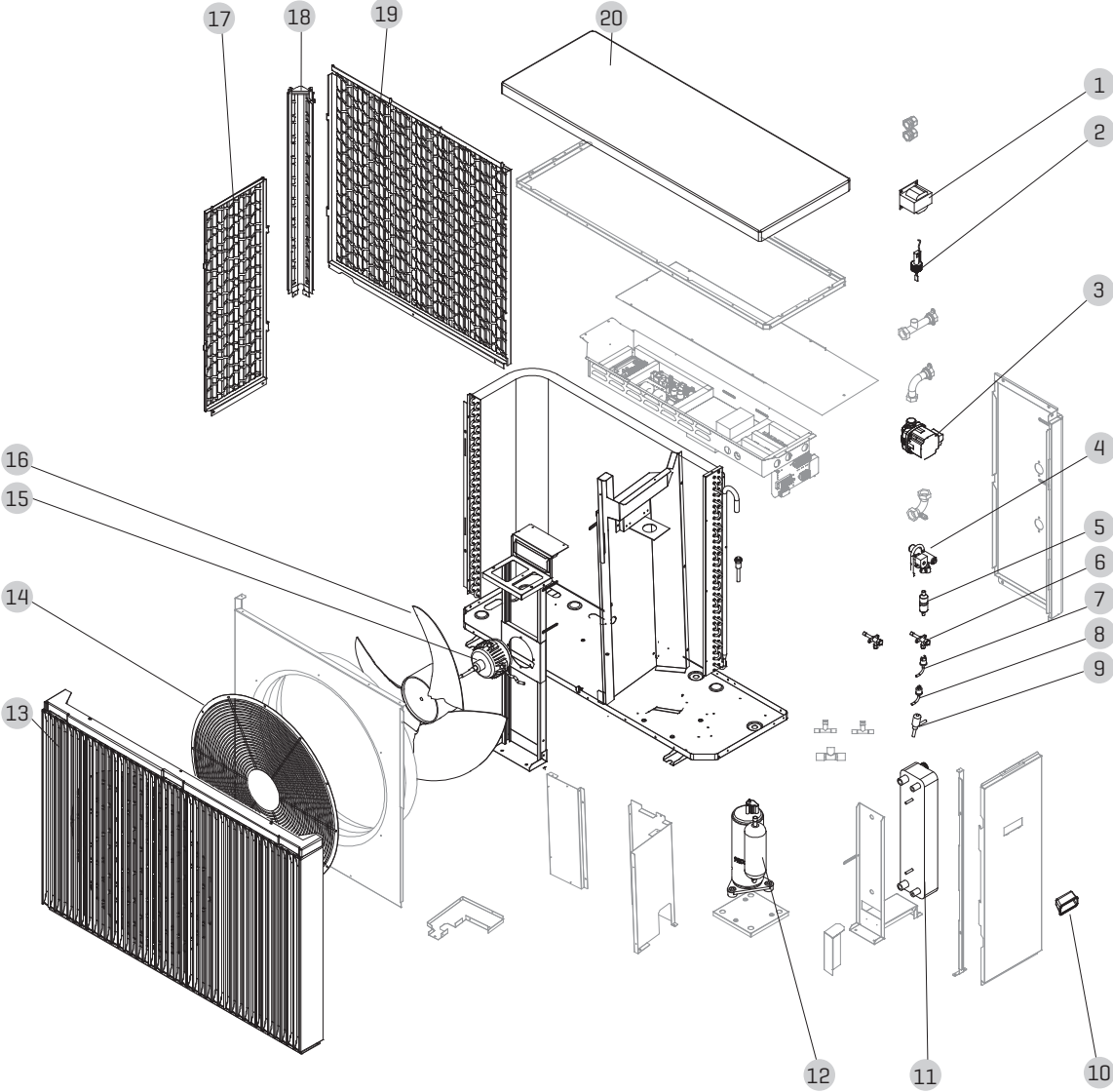

Explosion diagram of electrical box structure

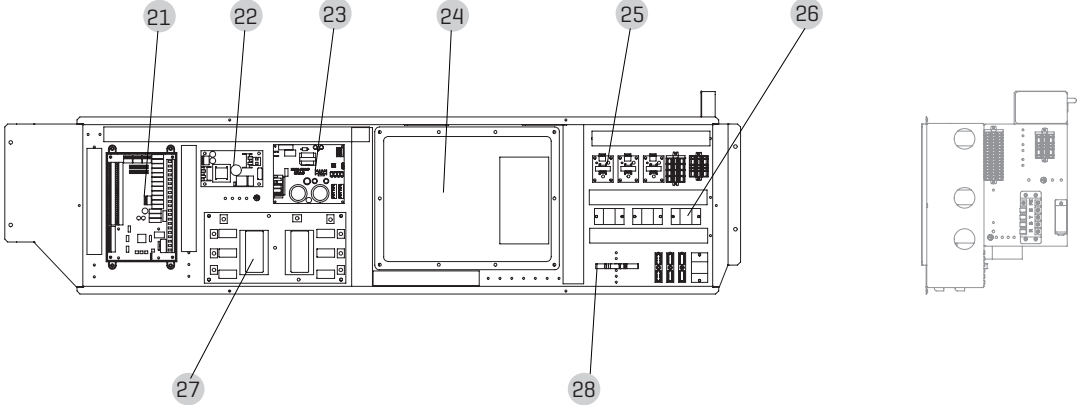

Number	Material code	Material name
1	86000037	Reactor
2	86000038	Water flow switch
3	86000039	Water pump
4	86000046	Four way valve and its accessories
5	86000054	Filter
6	86000028	Stop valve 3/8
7	86000052	Pressure switch [high]
8	86000053	Pressure switch [low]
9	86000049	Electronic expansion valve
10	86000041	Handle
11	86000043	Plate heat exchanger
12	86000057	Compressor and accessories
13	86000079	Front plate
14	86000031	Fan guard
15	86000061	DC fan motor
16	86000034	Axial fan blade
17	86000083	Side plate
18	86000082	Corner plate
19	86000081	Back plate
20	86000080	Top plate
21	86000065	Main board [PC4003-G]
22	86000066	Power switching module
23	86000071	Inverter board [ZL0001-G]
24	86000072	Inverter drive module
25	86000063	BHB21
26	86000064	Relay
27	86000073	Frequency inverter filter board
28	86000067	Fuse terminal

12.4. REN-HP-A-22S-V1

Explosion diagram of complete machine structure

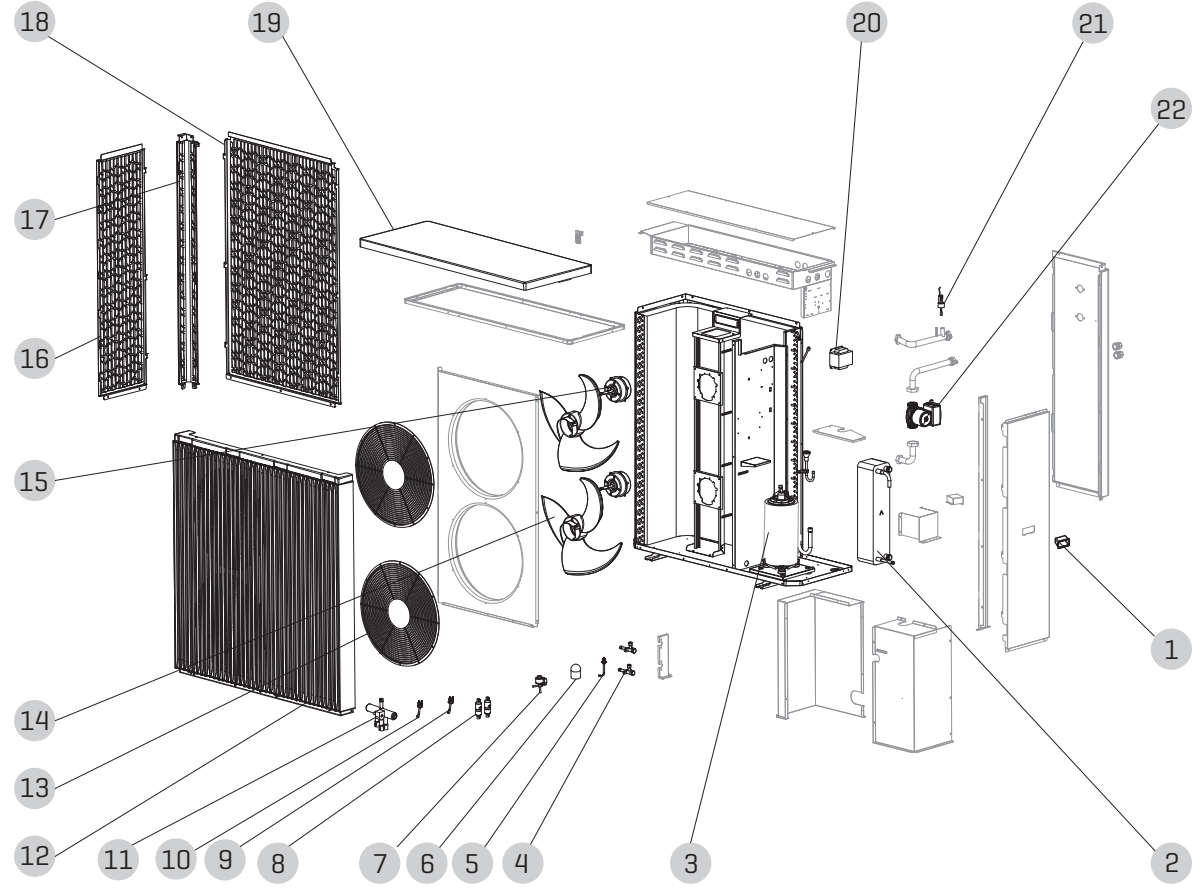

Explosion diagram of electrical box structure

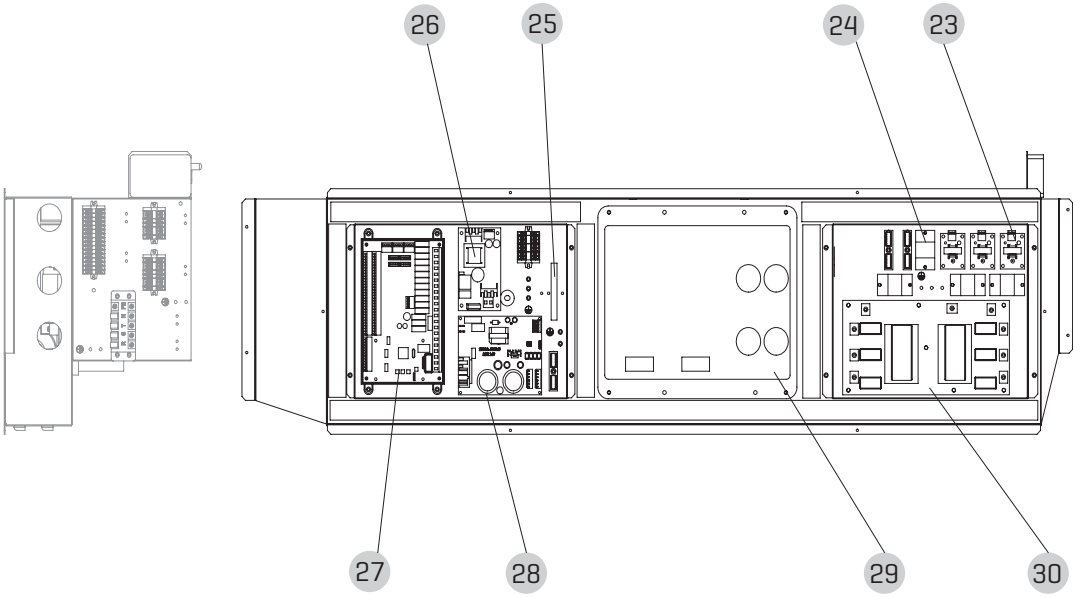

Number	Material code	Material name
1	86000041	Handle
2	86000044	Plate heat exchanger
3	86000058	Compressor and accessories
4	86000028	Stop valve 3/8
5	86000029	Needle valve
6	86000051	Pressure sensor
7	86000050	Electronic expansion valve
8	86000055	Filter
9	86000053	Pressure switch [low]
10	86000052	Pressure switch [high]
11	86000047	Four way valve and accessories
12	86000084	Front plate
13	86000032	Fan guard
14	86000035	Axial fan blade
15	86000062	DC fan motor
16	86000088	Side plate
17	86000087	Corner plate
18	86000086	Back plate
19	86000085	Top plate
20	86000037	Reactor
21	86000038	Water flow switch
22	86000040	Water pump
23	86000063	BHB21
24	86000064	Relay
25	86000067	Fuse terminal
26	86000066	Power switching module
27	86000065	Main board [PC4003-G]
28	86000071	Inverter board [ZL0001-G]
29	86000072	Inverter drive module
30	86000073	Frequency inverter filter board

14. FAILURE LIST & TROUBLESHOOTING

14.1. FAILURE HANDLING

Issue	Possible cause	Related components	Solution
Unit tripped when powered on	Short circuit	Terminals	Check all the components' connection
		Relays Contactors	Check relays and contactors whether they are broken
		Cable	Disconnect the electronic components one by one and power on to find the problem
Communication error	Cable has disconnected	Modbus cable	Check the modbus cable
	The power input cable is misconnected	Power input cable	Check the power cable Check the 3-phase power cable whether connected in right phase sequence
Unit doesn't start up	The unit has an error	Modbus	Check the modbus whether there is an error
	Cable is disconnected	Cables	Check the cable Reconnect the power cable and check if it works
Heating effect is not good	The compressor running low frequency	Compressor	Check the compressor frequency
	The fan is not running or speed is too low	Fan	Check the fan speed
	Leakage problem	Refrigerant system	Check the exhaust temperature and low pressure
Shut off while didn't reach the target temperature	Temperature limit (according to ambient temperature)	Control logic	Check the parameters
The evaporator has too much frost and cannot defrost cleanly	Parameter issue	Parameters	Check the defrosting parameters
	Fan blade or motor issue	Fan	Check the fan speed
	EEV step is not suitable	EEV	Check the compressor frequency
	Refrigerant amount issue	Refrigerant system	Check the exhaust temperature and low pressure
Abnormal noise	Screws issue	Screws	Check the screws
	Fan blade or motor issue	Fan	Check the fan blade and motor
	Compressor issue	Compressor	Check the compressor
	Components have collision	Other components (tubes, cables)	Check other components

14.2. ERROR CODE INSTRUCTIONS

Error code	Error name	Relevant parts information	Review and resolve
E04	Electric heater over heat protection		<ol style="list-style-type: none"> 1. Check if the electrical heating overheat protector is open or not. 2. Check the electrical heater.
E11	High pressure protection	HP switch is open	<ol style="list-style-type: none"> 1. Check whether showing the error after unit shutdown. 2. Measure the discharge pressure when unit is running. 3. Detect EEV step, suction pressure, inlet/outlet water discharge and suction temp. 4. Release all the gas of the system and refill refrigerant according to the nameplate.
E12	Low pressure protection	LP switch is open	<ol style="list-style-type: none"> 1. Check whether showing the error after unit shutdown. 2. Measure the suction pressure when unit is running. 3. Detect EEV step, discharge pressure, inlet/outlet water discharge and suction temp. 4. Release all the gas of the system and refill refrigerant according to the nameplate.
E19	Primary Anti-freezing Protection		This is the protection in winter.
E29	Secondary Anti-freezing Protection		This is the protection in winter.
E032	Flow Switch Protection	Flow switch is open	<ol style="list-style-type: none"> 1. Detect the connection of cables. 2. Detect the flow switch. 3. Detect the water valve is opened or opened fully. 4. Detect the water pump and the filter. 5. Maybe there is some air in the water piping route.
E051 E071	Compressor Over current Shutdown Fault	Compressor Over current	<ol style="list-style-type: none"> 1. Check ambient temp. and inlet/outlet water temp.; 2. Turn on the unit. Record and analyze the changing process of high/low pressure, discharge/suction temp., EEV step, compressor frequency and running current. 3. If they are OK, replace a new compressor driver board.
E065	High water outlet temp. protection		Check if the water flow is too low and the outlet water whether too high.
E081	Communication failure between PCB and fan drive board 1	Communication error between PCB and fan drive board	<ol style="list-style-type: none"> 1. Check the connection between PCB and fan board. All of 12V-12V, GND-GND, A-A, B-B should be closed. 2. If they are closed, turn on the power, then measure the voltage between 12V and GND on fan board, if higher than 15V or lower than 7V, replace a new fan board.
E082	Communication failure between PCB and fan drive board 2	Communication error between PCB and fan drive board	<ol style="list-style-type: none"> 1. Check the connection between PCB and fan board. All of 12V-12V, GND-GND, A-A, B-B should be closed. 2. If they are closed, turn on the power, then measure the voltage between 12V and GND on fan board, if higher than 15V or lower than 7V, replace a new fan board.
E103	Fan motor 1 overload protection		<ol style="list-style-type: none"> 1. Check if the fan motor is running well. 2. Detect the current of fan motor. 3. If the current is more than 1A, it means the motor has problem and needs to be replaced with a new one. 4. If the current is less than 1A, it means the motor control module ha a problem and needs to be replaced with a new one.
E203	Fan motor 2 overload protection		<ol style="list-style-type: none"> 1. Check if the fan motor is running well. 2. Detect the current of fan motor. 3. If the current is more than 1A, it means the motor has problem and needs to be replaced with a new one. 4. If the current is less than 1A, it means the motor control module ha a problem and needs to be replaced with a new one.
E171	Anti-freezing Protection		<ol style="list-style-type: none"> 1. Check the water flow. 2. Check the outlet water temp sensor. 3. Measure the ambient temp. 4. Detect the connection of cables. 5. Check the record of defrosting, whether the defrosting time is too long or too often.

Error code	Error name	Relevant parts information	Review and resolve
F00 F01 F33	Compressor start failure		Restart the unit. 1. Check the changing process of EEV step, high pressure, low pressure, inlet/outlet water temp. 2. Check the connection of U/V/W between compressor and compressor driver board. 3. Check the compressor resistance. 4. Check compressor driver board.
F03	Pre-charge failure		Restart the unit. 1. Check if the power supply connection and voltage supply is stable or not. 2. Replace with a new compressor driver board.
F05	DC Bus Over voltage		1. Check the voltage between DCP-IN and DCN-IN, if lower than 300V, the unit will get this protection. 2. Check the input voltage of R/S/T on compressor driver board, if lower than 210V, the unit will get this protection. 3. If they are OK, please replace a new compressor driver board.
F06	DC Bus Under voltage		1. Check the voltage between DCP-IN and DCN-IN, if lower than 300V, it will get this protection; 2. Check the input voltage of R/S/T on compressor driver board, if lower than 210V, it will get this protection; 3. If they are OK, please replace a new compressor driver board
F07	AC Input Under voltage		1. Measure the input voltage of R/S/T of driver board, if lower than 300V, it will get this protection. 2. If it's OK, replace a new compressor driver board.
F08	AC Input Over current		Only in single phase unit. Restart the unit. Check if there is electric leakage. If not, replace with a new drive board.
F09	Input voltage sampling fault		1. Make sure power supply is not lower than 300V or higher than 500V. 2. If it's OK, please replace a new compressor driver board.
F10	Communication Failure between DSP and PFC		Only in single phase unit. 1. Check the inverter board connection. 2. If no problem, replace with a new compressor driver board.
F11	Communication Fault between DSP and Communication board		1. Please check the inverter board connection. 2. If no problem, please replace with a new compressor driver board
F12	Communication failure between PCB and driver board		1. Check the connection between main control board and compressor driver board. All of 12V-12V, GND-GND, A-A, B-B should be closed. 2. If they are closed, turn on the power, then measure the voltage between 12V and GND on compressor driver board, if higher than 15V or lower than 7V, please replace with a new one compressor driver board.
F13	IPM Overheat Stop		1. Check if the fans are running or not. 2. Check the installation distance and space. 3. Leave enough distance and space so the heat pump has a good transfer heating condition. 4. Clean the finned heat exchanger. 5. If they are OK, replace with a new compressor driver board.
F15	Input voltage Lacking Phase		1. Check the phase of power supply R/S/T to compressor driver board. 2. If it's OK, replace with a new compressor driver board.
F16	Compressor weak magnetic protection alarm		1. Check the refrigeration system. 2. If it's OK, replace with a new compressor driver board.
F17	Temperature fault of drive board		1. Check the connection of heat sink temp. sensor. 2. Check the resistance of heat sink temp. sensor. 3. If they are OK, please replace with a new heat sink and heat sink temp. sensor.

Error code	Error name	Relevant parts information	Review and resolve
F18	IPM Current Sampling Fault		<ol style="list-style-type: none"> 1. Check ambient temp. and inlet/outlet water temp. 2. Check high/low pressure and discharge temp. and suction temp. 3. Check EEV step. 4. Check the compressor frequency and current. 5. If they are OK, replace with a new compressor driver board.
F20	IGBT Power Device Overheat Alarm		<ol style="list-style-type: none"> 1. Check the if fans are running or not. 2. Check the installation distance and space. 3. If they are OK, please replace with a new compressor driver board. 4. Leave enough distance and space to make heat pump have a good transfer heating condition. 5. Clean air to fin heat exchanger.
F22	AC input over current protection alarm		<p>Only in single phase unit. Restart the unit.</p> <ol style="list-style-type: none"> 1. Check if there is electric leakage. 2. If still have the failure, replace with a new drive board.
F23	EEPROM Fault Alarm		<ol style="list-style-type: none"> 1. Check the connection. 2. Replace with a new driver board.
F24	Destroyed EEPROM Activation Ban Alarm		
F25	LP 15V Under load Fault		<ol style="list-style-type: none"> 1. Check the power supply is stable or not, and restart unit. 2. If the problem is still on, please replace with a new drive board.
F26	IGBT Power Device Overheat Fault		<ol style="list-style-type: none"> 1. Check if the fans are running or not. 2. Check the installation distance and space. 3. Leave enough distance and space so the heat pump has a good transfer heating condition. 4. Clean the finned heat exchanger. 5. If they are OK, please replace with a new driver board.
F031	DC Fan Motor 1 Failure		<ol style="list-style-type: none"> 1. Turn off the unit and check the connection. 2. Restart and check if the motor is running normal or the error happens again. 3. Replace with a new fan motor.
F032	DC Fan Motor 2 Failure		
P11	Suction Pressure Sensor Fault		<ol style="list-style-type: none"> 1. Detect the suction pressure sensor connection. 2. If the connection is OK, please replace with a new one.
TP	Low Ambient Temp. Protection	Ambient temp ≤ -30	<ol style="list-style-type: none"> 1 Check the ambient temp. 2. When ambient temp ≥ -28°C, the fault will disappear.
P01	Water Inlet Temp. Sensor Fault		<ol style="list-style-type: none"> 1. Detect the connection. 2. Measure the resistance of sensor, if lower than 100Ω or higher than 500kΩ, please replace with a new one.
P02	Water Outlet Temp. Sensor Fault		
P04	Ambient Temp. Sensor Fault		
P17	Suction Outlet Temp. Sensor Fault		
P032	Hot Water Tank Temp. Sensor Fault		
P153	Coil Temp. Sensor Fault		
P181	Exhaust Temp. Sensor Fault		
P182	Exhaust Over Temp.	[Exhaust temp.] ≥ C05 default 110	<ol style="list-style-type: none"> 1. Measure the resistance of sensor, if lower than 100Ω or higher than 500kΩ, please replace with a new one. 2. Check the unit find if it has refrigerant leakage.
P191	Antifreeze Temp. Sensor Fault		<ol style="list-style-type: none"> 1. Detect the connection. 2. Measure the resistance of sensor, if lower than 100Ω or higher than 500kΩ, please replace with a new one.

15. APPENDIX

15.1. CAUTION & WARNING

1. The unit can only be repaired by qualified installers or an authorized dealer.
2. This appliance is not intended to be used by persons [including children] with reduced physical sensory or mental capabilities, or lack of experience and knowledge, unless they have been given supervision or instruction concerning the use of the appliance by a person responsible for their safety. Children should be supervised to ensure that they do not play with the appliance.
3. Please make sure that the unit and power connection have good earthing, otherwise this may cause electrical shock.
4. If the supply cord is damaged, it must be replaced by the manufacturer or our service agent or similarly qualified person in order to avoid a hazard.
5. Directive 2002/96/EC [WEEE]:
The symbol depicting a crossed-out waste bin that is underneath the appliance indicates that this product, at the end of its useful life, must be handled separately from domestic waste. It must be taken to a recycling center for electric and electronic devices or handed back to the dealer when purchasing an equivalent appliance.
6. Directive 2002/95/EC [RoHS]: This product is compliant with directive 2002/95/EC [RoHS] concerning restrictions for the use of harmful substances in electric and electronic devices.
7. The unit CANNOT be installed near the flammable gas. Once there is any leakage of the gas, fire can occur.
8. Make sure that there is circuit breaker for the unit, lack of circuit breaker can lead to electrical shock or fire.
9. The heat pump located inside the unit is equipped with an over-load protection system. It does not allow for the unit to start for at least 3 minutes from a previous stoppage.
10. Use a supply wire suitable for 75°C.
11. Caution: Single wall heat exchanger, not suitable for potable water connection.

15.2. WARRANTY TERMS AND CONDITIONS FOR THE USER

The warranty is valid for two years. The installation and maintenance must be done according to the instructions and rules. Please visit our website, www.renson.eu, for the detailed warranty terms and conditions.

Exclusions:

The penetration of construction debris, the injection of other products than the appropriate products, use of aggressive liquids or solvents, defects resulting from incorrect or abnormal usage, small imperfections in the finish that have no effect on the reliability, damage due to paint, damage due to drilling, defects due to unprofessional repairs done by third parties, voltage spikes on the mains supply, lightning strikes, violence, or war.

The proof of warranty is included in the packaging. The installer will fill this in and hand it over to the home owner.

15.3. SERVICE

Please contact your RENSON® installer, stating the warranty number and manufacturing date, to request that your unit be serviced for maintenance.



RENSON® Headquarters
Maalbeekstraat 10, IZ 2 Vijverdam, B-8790 Waregem, Belgium
Tel. +32 56 30 30 00
info@renson.eu
www.renson.eu

